

### Model RMK-II

DO NOT INSTALL THE ANTENNA IN A PLACE WHERE ANY PART OF IT CAN COME INTO CONTACT WITH POWER LINES IN THE EVENT OF STRUCTURAL FAILURE OF ANY PART OF THE INSTALLATION OR IN THE COURSE OF NORMAL FLEXING AFTER INSTALLATION, FOR SUCH CONTACT CAN RESULT IN DAMAGE TO PROPERTY, BODILY INJURY, OR DEATH!

DURING ASSEMBLY AND INSTALLATION TAKE CARE TO AVOID CONTACTING POWER LINES WITH THE ANTENNA OR ANY PART OF THE RADIAL OR GROUND SYSTEM. DO NOT RUN ANY WIRES ABOVE OR BELOW POWER LINES.

TO AVOID A POSSIBLE SHOCK HAZARD CONNECT ALL STATION EQUIPMENT TO A GOOD EARTH GROUND. FOR GREATER SAFETY, DISCONNECT ALL STATION EQUIPMENT FROM A.C. POWER BEFORE PROCEEDING.

1. Install the tripod tower at the peak of the roof as shown. Use three lag screws per base plate to secure the tower firmly to the roof.

NOTE: The lag screws are best installed if a 1/8" starter hole is first made for each.

NOTE: Although leaks are not usually a problem, you may wish to place a 3 1/4" strip of Konnektor-Kote™ (supplied) under each base plate. In addition, you may wish cover the three base plates with sealant.

2. Loosen the set screws at the top and middle of the tower and install the MPS Mounting Post Sleeve. The slotted end with the hose clamp should be up.
3. Tighten the set screws to secure the 1 1/4" tube finger tight. Do not over tighten, as this will damage the tube and keep the mounting post from sliding smoothly.
4. Install the assembled antenna by sliding the (A) mounting post into the MPS as far as it will go and tighten the hose clamp. NOTE: If the roof is steep or if there is no one to assist you in raising the antenna, you may wish to install the antenna in the tripod lying on its side and walk or pull the antenna up, hinging it on two of the tripod's base plates. Alternatively, the mounting post may be installed and the antenna placed on top of it.

**WARNING: SAFETY FIRST!** Although the antenna is not heavy, it may be hard to handle alone or in windy conditions. A safety belt should always be used when working above ground level.

5. Securely tighten both set screws and lock nuts.
6. Connect the four STR's to the grounding screw on the (A) mounting post or solder them to the extra wire coming from the (Q) coil. For antennas from other manufacturers, connect the STR's to the same point as the braid of the coaxial feedline.

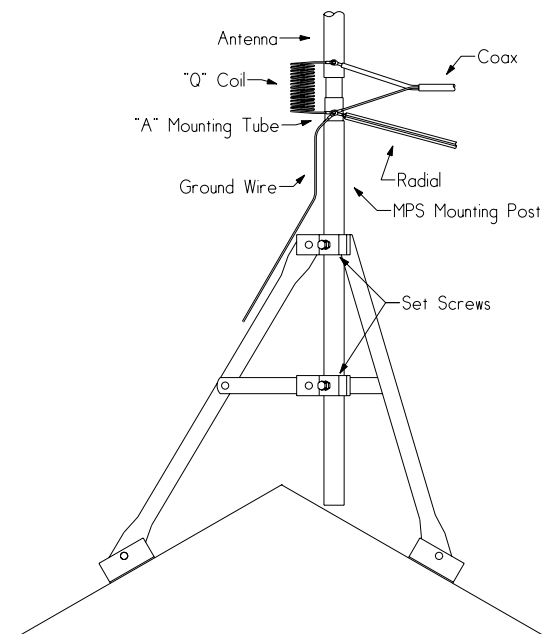

7. Fan out the four STR's and tie off the insulated ends.

NOTE: The STR's should not be pulled too tight, but neither should they be allowed to droop onto the roof or to touch other objects, especially metallic ones. Ideally, the STR's should be spaced with 90 degrees of separation between adjacent wires, but they will work well enough in other configurations if space is limited.

8. If operation on 30 meters with the Butternut HF6V-X/HF9V-X is intended, cut four 24 ft radials from the 200 ft. roll of wire. Attach an insulator to one end of each wire. Attach the other end to the grounding screw on the (A) mounting post or solder them to the extra wire coming from the (Q) coil.

9. Fan out the four 30 meter radials between the STR's and tie off the insulated ends.

NOTE: Fewer than four radials may be used if necessary, but two such radials running in opposite directions to each other should be considered the minimum number for effective performance.

10. Cut one or more 80/75 meter radials to the proper length for the desired band segment. The proper length, in feet, may be found by dividing 234 by the desired frequency in MHz, e.g.,  $234/3.9 \text{ MHz} = 60 \text{ ft}$ . Attach an insulator to one end of each wire. Attach the other end to the grounding screw on the (A) mounting post or solder them to the extra wire coming from the (Q) coil.

NOTE: Be sure that all radials are spaced as evenly as possible from each other along their length in order to avoid interaction that could cause detuning. If any radial must be bent because of limited space, try to avoid bends sharper than 90 degrees.

11. Connect the ground side of the antenna to a good earth ground using heavy gauge wire. Use as short a lead as possible.

NOTE: This ground is required for protection from lightning and static discharge.

12. Connect the coaxial feedline.

13. Check for resonance or low-VSWR operation of the antenna according to the manufacturer's instructions.

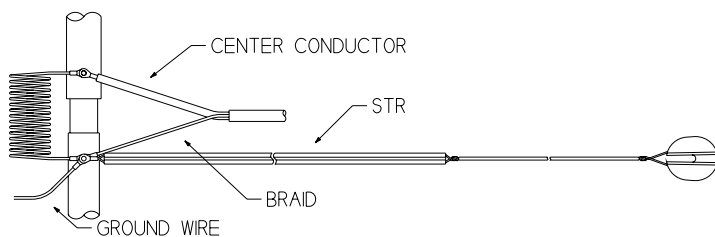

This diagram shows a typical connection. STR's and single wire radials may be connected in other ways so long as they are connected close to the braid of the coaxial cable. All radials may slope downward from the antenna by as much as 45 degrees, but their far ends should not be less than several meters above the earth for best

results. In windy areas light nylon twine or monofilament line may be used to support the weight of the STR's along their length and to dampen vibration that can cause their relatively light conductors to break.

### PARTS LIST

- 4 V00342 Resonant Radial
- 1 V00344 Wire Bundle
- 5 V00345 Insulator
- 1 V00305 MPS Mounting Post Sleeve
- 1 V00232 Tripod 2'
- 9 V00231 1/4" x 2" Lag Screw
- .07 V00050 Konnektor-Kote (1 x 10")